

State Planning Policy 3.1

Residential Design Codes

(Variation 1)

Codes

Prepared under section 26 of the
Planning and Development Act 2005
by the Western Australian Planning Commission.

Varies State Planning Policy 3.1 as published
in the Government Gazette 4 October 2002.



Department for Planning
and Infrastructure

April 2008

State Planning Policy 3.1

Residential Design Codes (Variation 1)

Disclaimer

This document has been published by the Western Australian Planning Commission. Any representation, statement, opinion or advice expressed or implied in this publication is made in good faith and on the basis that the government, its employees and agents are not liable for any damage or loss whatsoever which may occur as a result of action taken or not taken, as the case may be in respect of any representation, statement, opinion or advice referred to herein. Professional advice should be obtained before applying the information contained in this document to particular circumstances.

© State of Western Australia

Published by the
Western Australian Planning Commission
Albert Facey House
469 Wellington Street
Perth WA 6000

Published April 2008

ISBN 0 7309 9643 3

website: www.wapc.wa.gov.au
email: corporate@wapc.wa.gov.au

tel: 08 9264 7777
fax: 08 9264 7566
TTY: 08 9264 7535
infoline: 1800 626 477

Western Australian Planning Commission owns all photography in this document unless otherwise stated. This document is available in alternative formats on application to WAPC Communication Services.

Contents

Part 1 - Preliminary

- 1.1 Citation
- 1.2 Purpose of the R-Codes
- 1.3 General objectives of the R-Codes
- 1.4 Application of the R-Codes
- 1.5 Explanatory guidelines

Part 2 - Codes approval process

- 2.1 Planning approval
- 2.2 Single house approvals
- 2.3 Planning approval for single houses on small lots
- 2.4 Discretionary decisions
- 2.5 Exercise of discretion

Part 3 - Accompanying information

- 3.1 Applications for planning approval
- 3.2 Applications for codes approval
- 3.3 General information requirements
- 3.4 Existing site analysis plan
- 3.5 Proposed development site plan
- 3.6 Special information requirements

Part 4 - Neighbour consultation

- 4.1 Consultation requirement
- 4.2 Consultation procedure
- 4.3 Opportunity to respond

Part 5 - Local planning policies

- 5.1 Local planning policies consistent with codes
- 5.2 Pre-existing local planning policies
- 5.3 Scope of local planning policies

Part 6 - Design elements

- 6.1 Housing density requirements
- 6.2 Streetscape requirements
- 6.3 Boundary setback requirements
- 6.4 Open space requirements
- 6.5 Access and parking requirements

- 6.6 Site works requirements
- 6.7 Building height requirements
- 6.8 Privacy requirements
- 6.9 Design for climate requirements
- 6.10 Incidental development requirements

Part 7 - Special provisions

- 7.1 Special purpose dwellings requirements
- 7.2 Mixed use development requirements
- 7.3 Inner city housing requirements

Appendices

- Appendix 1 - Definitions
- Appendix 2 - Codes approval application form
- Appendix 3 - Codes approval decision form
- Appendix 4 - Adjoining property owner comment form
(discretionary approval application under the Residential Design Codes)

Tables

- Table 1 - General site requirements
- Table 2a and 2b - Boundary setbacks
- Table 3 - Maximum building heights

Figures

- Figure 1a, 1b and 1c - Street setbacks
- Figure 2a, 2b and 2c - Measurements of boundary setbacks
- Figure 2d and 2e - Measurements of boundary setbacks
- Figure 3 - Boundary setbacks

State Planning Policy 3.1

Residential Design Codes

(Variation 1)

R-Codes

Part 1 - Preliminary

- 1.1 Citation
- 1.2 Purpose of the R-Codes
- 1.3 General objectives of the R-Codes
- 1.4 Application of the R-Codes
- 1.5 Explanatory guidelines



State Planning Policy 3.1

Residential Design Codes (Variation 1)

Part 1 - Preliminary

1.1 Citation

This state planning policy is made under section 26 of the *Planning and Development Act 2005*. This policy may be cited as State Planning Policy 3.1 Residential Design Codes (Variation 1) or R-Codes.

1.2 Purpose of the R-Codes

The purpose of the R-Codes is to provide a comprehensive basis for the control, through local government, of residential development throughout Western Australia.

1.3 General objectives of the R-Codes

The R-Codes have the following objectives.

1.3.1 Objectives for residential development

- (a) To provide for a full range of housing types and densities that meet the needs of all people.
- (b) To provide for local variations in neighbourhood character.
- (c) To ensure appropriate standards of amenity for all dwellings.
- (d) To ensure provision of on-site facilities for all dwellings.
- (e) To protect the amenity of adjoining residential properties.
- (f) To encourage the conservation of buildings with heritage value.
- (g) To encourage environmentally sensitive design.

1.3.2 Objectives for the planning and development process

- (a) To provide local government with the full range of choices for housing type and design, to meet the needs of their communities.
- (b) To provide for uniformity of residential development standards, consistent with local needs.
- (c) To provide clear and understandable siting and design standards.
- (d) To minimise cost and delay in the process of preparing, assessing and determining development applications.
- (e) To provide for neighbour consultation and discretionary decisions by councils where acceptable development provisions are not met.

1.3.3 Application of objectives

In assessing and determining applications for residential development, the council shall have regard to these general objectives, and any specific objectives set out in the R-Codes.

1.4 Application of the R-Codes

The R-Codes apply throughout Western Australia.

1.5 Explanatory guidelines

The Western Australian Planning Commission (WAPC) may prepare more detailed explanatory guidelines on the matters addressed in the R-Codes, in consultation with local government and relevant stakeholders, to meet the objectives of the codes and, if prepared, these should be taken into account in the determination of proposals.



State Planning Policy 3.1

Residential Design Codes (Variation 1)

State Planning Policy 3.1

Residential Design Codes

(Variation 1)

RCodes

Part 2 - Codes approval process

- 2.1 Planning approval
- 2.2 Single house approvals
- 2.3 Planning approval for single houses on small lots
- 2.4 Discretionary decisions
- 2.5 Exercise of discretion



State Planning Policy 3.1

Residential Design Codes (Variation 1)

Part 2 - Codes approval process

2.1 Planning approval

2.1.1

Where planning approval is required under the scheme, a planning application shall be lodged with the relevant council for approval.

2.1.2

The planning application should provide details regarding the manner in which the requirements of the codes, being part of the scheme, are satisfied.

2.1.3

All residential development is to comply with the requirements of the codes and, notwithstanding that under any other provision of the scheme, residential development (including construction of a single house) may be exempted from or does not require planning approval, prior approval under and in accordance with the codes (codes approval) is required if the proposed residential development:

- (a) does not conform with the acceptable development provisions of parts 6 and 7; or
- (b) requires the exercise of discretion by council in respect of any matter under the codes.

2.2 Single house approvals

Where the development of a single house does not require planning approval under the scheme, but that development requires the exercise of discretion under the codes:

- (a) An application shall be made in accordance with the form set out in appendix 1 or a suitable form pursuant to the scheme for the exercise of discretion under the codes prior to the issue of a building licence.

- (b) The application shall contain such details as are required in part 3 or such information as is required by council from time to time under a local planning policy.
- (c) The decision of the council shall be conveyed in writing to the applicant in the form included in appendix 3 and shall have effect from the date of the decision.

2.3 Planning approval for single houses on small lots

Notwithstanding clause 8.2 (b) of the Model Scheme Text, and any other provision of the scheme, planning approval is required for the erection of a single house on any lot smaller than 350 sq m.

2.4 Discretionary decisions

In relation to the codes, discretionary decisions shall be decisions made by the council with respect to any aspect of a proposed development that varies from the relevant acceptable development provision or a provision of a local planning policy.

2.5 Exercise of discretion

2.5.1

Where codes approval is required, the applicant shall make an application in accordance with the form set out in appendix 2 to the council for approval. Subject to clauses 2.5.2 and 2.5.3, the council is to exercise its discretion in considering such applications having regard to the considerations, standards and requirements provided in the codes.

State Planning Policy 3.1

Residential Design Codes (Variation 1)

2.5.2

Discretion shall be exercised having regard to the following considerations:

- (a) the stated purpose and aims of the scheme;
- (b) the provisions of parts 1-7 of the codes, as appropriate;
- (c) the performance criterion or criteria in the context of the coding for the locality that corresponds to the relevant provision;
- (d) the explanatory guidelines of the codes that correspond to the relevant provision;
- (e) any local planning strategy incorporated into the scheme;
- (f) a provision of a local planning policy pursuant to this policy and complying with clause 2.5.3; and
- (g) orderly and proper planning.

2.5.3

A council shall not vary the minimum or average site area per dwelling requirements set out in table 1 except as provided in the codes or in the scheme.

2.5.4

A council shall not refuse to grant approval to an application in respect of any matter where the application complies with the relevant acceptable development provision and the relevant provisions of the council's planning scheme or a local planning policy.

2.5.5

For the purpose of the codes, a local planning policy will be a relevant consideration in the exercise of discretion where the policy:

- (a) is specifically sanctioned by a provision of the codes; and
- (b) is not inconsistent with the codes.

State Planning Policy 3.1

Residential Design Codes

(Variation 1)

R Codes

Part 3 - Accompanying information

- 3.1 Applications for planning approval
- 3.2 Applications for codes approval
- 3.3 General information requirements
- 3.4 Existing site analysis plan
- 3.5 Proposed development site plan
- 3.6 Special information requirements



State Planning Policy 3.1

Residential Design Codes (Variation 1)

Part 3 - Accompanying information

3.1 Applications for planning approval

Where:

- (a) planning approval is required under the scheme;
- (b) the proposed development requires the council to exercise a discretion under the codes; or
- (c) the proposal is for the development of a lot of less than 350 sq m

an application shall be made to the council on the appropriate form.

3.2 Applications for codes approval

An application for codes approval shall be submitted to council under the Codes approval application form (appendix 2) in respect of residential development (including the construction of a single house) not otherwise requiring prior approval under another provision of the scheme where:

- (a) the proposed development does not conform with the acceptable development provisions set out in parts 6 and 7;
- (b) the proposed development requires the council to exercise a discretion under the codes; or
- (c) the proponent seeks assessment in accordance with the performance criteria of the codes.

In relation to an application for codes approval, the council shall issue its decision on the Codes approval decision form (appendix 3).

3.3 General information requirements

3.3.1

The requirements of 3.1 and 3.2 are applicable notwithstanding any other provision in the scheme. In any other cases where planning approval or codes approval is not required, information shall be submitted to demonstrate that the codes requirements have been satisfied for purposes of verification by council prior to council issuing a building licence.

3.3.2

Unless otherwise determined by council, residential development proposals shall be supported with information as to the development site, the proposed development, and adjoining properties contained in an existing site analysis plan, a proposed development site plan and drawings in accordance with 3.4 to 3.6.

3.4 Existing site analysis plan

3.4.1

An existing site analysis plan shall be provided at a scale of not less than 1:200 containing the following:

- (a) street name and lot number;
- (b) north point and scale bar;
- (c) all boundary and area dimensions;
- (d) existing levels to an established datum, including contours at maximum intervals of 0.5 m and spot levels at all boundaries at intervals not greater than 5 m;
- (e) the position and dimensions, horizontal and vertical, of existing buildings, retaining walls and other structures;
- (f) the position, type, and size of any tree exceeding 3 m in height;

- (g) the street verge, including footpaths, street trees, crossovers, power poles and any services such as telephone, gas, water and sewerage in the verge;
 - (h) location of service connections;
 - (i) location of any easement or piped service traversing the site and any sewer or sewer connection point servicing the site;
 - (j) location of any access restrictions such as road islands adjacent to the site; and
 - (k) the position of any adjoining and existing buildings that might affect, or be affected by, the proposed development, including the position of the proposed development, levels of habitable room windows, and outdoor living areas.
- (b) the horizontal position, floor levels and positions of all openings of any existing and proposed building or part of a building on the subject property where any such building is within 7.5 m of a side boundary;
 - (c) the position and levels of all proposed buildings, walls, fences, retaining walls and other structures;
 - (d) the position of paved vehicle, pedestrian access ways and parking spaces;
 - (e) structures and trees to be removed;
 - (f) areas to be landscaped;
 - (g) proposed finished levels over the site;
 - (h) the shadow that would be cast at noon on 21 June by any proposed building onto an adjoining property for any proposed development; and
 - (i) the proposed site area boundaries of any strata lots.

3.4.2

It is desirable for the site analysis plan to include the following:

- (a) the direction of cooling breezes and areas exposed to winter sun;
- (b) the most favourable locations for outdoor living areas (generally, on the north);
- (c) desirable views; and
- (d) photographs or drawings of the street elevations of any existing buildings on site and on the adjoining sites, showing height, roof and wall materials, windows and roof pitch.

3.5

Proposed development site plan

3.5.1

A proposed development site plan (which may be combined with the plan described in clause 3.4) shall be provided at a scale of not less than 1:200 showing the following:

- (a) site dimensions, scale bar, north point, and existing contours and levels as described in 3.4;

3.5.2

The site development plan shall be supported by drawings at a scale of not less than 1:100 which show:

- (a) all floor plans and their distances from the boundaries of the site;
- (b) all elevations, with the existing and natural ground levels, wall heights and roof heights related to the common datum;
- (c) cross-sections through any proposed areas of excavation or filling with the relevant existing, natural and proposed levels related to the datum; and
- (d) proposed materials, colours and finishes of the exterior of the building.

3.6 Special information requirements

The following additional information shall be provided where necessary to enable proper assessment of specific provisions of the codes or matters required to be assessed against performance criteria.

- (a) A written justification, where an acceptable development provision of the codes has not been satisfied, or cannot be satisfied, and the proposal relies on satisfying a performance criterion, or a submission that the performance criterion is irrelevant or cannot be met.
- (b) Where a proposed major opening to an active habitable space is less distant from the nearest point of common boundary than the setbacks set out in design element 6.8, the following information shall be provided:
 - (i) The position and dimensions of any balcony or major openings to any active habitable space in any wall of an adjoining building which is visible from the development site and is located within 6 m of a boundary of the development site.
 - (ii) The position and level of any accessible area (eg lawn, paving, decking, balcony or swimming pool) on any adjoining property and within 6 m of a boundary of the development site.
 - (iii) Provision of additional or marked-up plans and sections showing the cone of vision and critical lines of sight from those major openings as they relate to the adjoining property.
 - (iv) Details of screening or other measures proposed to be used to reduce overlooking.
- (c) Where a proposed building does not meet the acceptable development provisions relating to overshadowing set out in design element 6.9, provision of plans and sections of sufficient information to explain how the adjoining property as a whole would be affected by overshadowing.
- (d) Where an existing place on the State Heritage Register or the heritage list of the scheme is proposed to be demolished, or its external appearance significantly altered:
 - (i) a copy of any heritage assessment or report or conservation plan that has previously been carried out for the place;
 - (ii) photographs of the place or parts of the place proposed to be affected; and
 - (iii) a justification for the proposal, as in 3.6 (a).
- (e) In the case of proposed multiple dwelling developments and for all proposed developments which include communal open space, the provision of a landscape development plan covering the matters set out in 6.4.5 of design element 6.4. Such a plan may, if the proponent chooses, be in outline form in the initial application, subject to submission and approval of the detailed plan, including a written maintenance manual, prior to the issue of a building licence.
- (f) In the case of proposed aged or dependent persons' dwelling developments under part 7, the provision of sufficient plans and accompanying information to demonstrate compliance with the relevant provisions of AS4299:1995.



State Planning Policy 3.1

Residential Design Codes (Variation 1)

State Planning Policy 3.1

Residential Design Codes

(Variation 1)

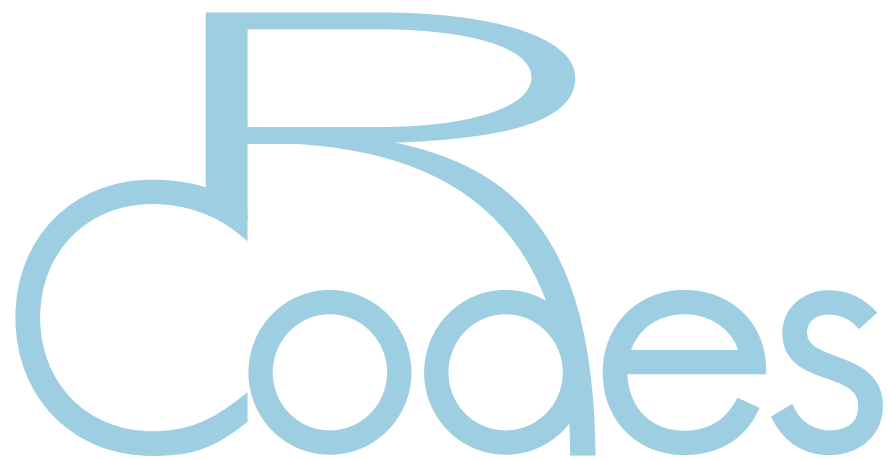
A large, light blue graphic of the word 'Codes' is centered on the page. The letter 'R' is significantly larger and more stylized than the other letters, which are in a clean, sans-serif font.

Part 4 - Neighbour consultation

- 4.1 Consultation requirement
- 4.2 Consultation procedure
- 4.3 Opportunity to respond



State Planning Policy 3.1

Residential Design Codes (Variation 1)

Part 4 - Neighbour consultation

4.1 Consultation requirement

In the case of a proposed development that:

- (a) requires the exercise of a discretion by the council under the codes or under an adopted local planning policy; and
- (b) may, in the opinion of the council, adversely affect the amenity of an adjoining property,

the provisions of 4.2 and 4.3 apply to provide for affected property owners to view and comment on the proposal.

In any other case the council may, at its discretion, inform adjoining owners and occupiers of the nature of proposals received.

4.2 Consultation procedure

4.2.1

Potentially affected owners of adjoining properties, as identified by the council, shall be notified of:

- (a) the site and general nature of the proposals;
- (b) the nature of the discretionary decision involved;
- (c) the availability of details of the proposals at the council premises; and
- (d) the adjoining property owner comment form (appendix 4) which must be used when providing comments on the proposals; and
- (e) the last date by which any comments are to be lodged with the council, being at least fourteen (14) days after date of posting of notification, and invited to comment on that part of the proposed development that does not meet the acceptable development requirements of the codes.

4.2.2

Where no response is received within the time specified from the date of notification, the council may determine the application without the affected owner's response.

4.2.3

As an alternative, a council may permit such notification to be carried out by the applicant, subject to the notification of the information in 4.2.1 and proof of posting by registered post provided to the council.

4.2.4

Where a council considers a proposal to be unacceptable it may refuse the application without undertaking neighbour consultation.

4.3 Opportunity to respond

4.3.1

Where comments are received from affected property owners, the council shall provide the applicant with the opportunity to respond to the council.

4.3.2

A summary of all comments received in response to an invitation under 4.2 shall be provided to the applicant on request and, if so requested, a period of not more than 10 days should be allowed within which the applicant may submit a response to the comments prior to the council considering the application.



State Planning Policy 3.1

Residential Design Codes (Variation 1)

State Planning Policy 3.1

Residential Design Codes

(Variation 1)

R Codes

Part 5 - Local planning policies

- 5.1 Local planning policies consistent with codes
- 5.2 Pre-existing local planning policies
- 5.3 Scope of local planning policies



State Planning Policy 3.1

Residential Design Codes (Variation 1)

Part 5 - Local planning policies

5.1 Local planning policies consistent with codes

Subject to 5.3, a local planning policy that affects residential development shall be consistent with the provisions of the codes and may not provide for greater or lesser requirements than the codes unless expressly permitted under the codes.

5.2 Pre-existing local planning policies

If a properly adopted local planning policy which came into effect prior to the gazettal of the codes is inconsistent with the codes, the codes prevail over the policy to the extent of the inconsistency.

5.3 Scope of local planning policies

5.3.1

Local planning policies may contain provisions that:

- (a) vary or replace the following acceptable development provisions set out in the codes: streetscape (design element 6.2 A1-A6); building design (design element 6.2 A7-A9); boundary walls (design element 6.3 A2); site works (design element 6.6 A1.4); building height (design element 6.7 A1); external fixtures (design element 6.10 A2.3 - A2.4); special purpose dwelling requirements or aged or dependent person's dwellings (part 7.1.2 A2 ii); mixed use development (part 7.2) and inner city housing (part 7.3); or
- (b) augment the codes by providing additional performance criteria and acceptable development provisions for any aspect of residential development that is not provided for in the codes.

5.3.2

Despite clause 5.3.1, a council may, with the approval of the WAPC, vary any other acceptable development provision within the codes by means of a local planning policy where it can be demonstrated to the satisfaction of the WAPC that there is a need specific to a particular region that warrants such a variation.



State Planning Policy 3.1

Residential Design Codes (Variation 1)

State Planning Policy 3.1

Residential Design Codes

(Variation 1)

R Codes

Part 6 - Design elements

- 6.1 Housing density requirements
- 6.2 Streetscape requirements
- 6.3 Boundary setbacks requirements
- 6.4 Open space requirements
- 6.5 Access and parking requirements
- 6.6 Site works requirements
- 6.7 Building height requirements
- 6.8 Privacy requirements
- 6.9 Design for climate requirements
- 6.10 Incidental development requirements



State Planning Policy 3.1

Residential Design Codes (Variation 1)

Part 6 - Design elements

6.1 Housing density requirements

Objective

To ensure that residential development occurs in line with community expectations about its type and density.

Performance criteria	Acceptable development
<p><i>New development should meet these criteria.</i></p>	<p><i>The acceptable development provisions illustrate one way of meeting the associated performance criteria.</i></p> <p>Note: The minimum areas stipulated in table 1 are not subject to variation except as set out in clauses 6.1.2 and 6.1.3 of this element.</p>
<p>6.1.1 Site area requirements</p>	
<p>P1 Development of the type and density indicated by the R-Code designated in the scheme.</p>	<p>A1.1 Development which complies with the dwelling type and site area requirements set out in table 1 and the following provisions.</p> <p>A1.2 The minimum site area set out in table 1 is calculated as follows:</p> <ul style="list-style-type: none"> i in the case of a single house, the area of a green title lot or survey-strata lot; or ii in the case of a grouped dwelling, the area of land occupied by the dwelling itself, together with all other areas whether contiguous or not, designated for the exclusive use of the occupants of that dwelling; or iii in the case of multiple dwellings, the total area of the lot divided by the number of dwellings.

6.1.2

Additional site area requirements/concessions

- P2 Development of dwellings of a type and density indicated by the R-Codes designated in the scheme.
- A2 For the purposes of assessing compliance of a proposed development with the minimum and average site areas set out in table 1, the following adjustments for the purposes of calculating the minimum and average site area shall apply:
- i in the case of a lot with a corner truncation, up to a maximum of 20 sq m of that truncation shall be added to the area of the adjoining lot, survey strata lot or strata lot as the case may be; or
 - ii in the case of a rear battleaxe site, the site area is inclusive of the access leg provided that the area of the access leg contributes no more than 20 per cent of the site area as required by table 1. Where the lot (excluding the access leg) adjoins or abuts a right-of-way or reserve for open space, pedestrian access, school site or equivalent, half the width (up to a maximum depth of two metres) may be added to the site area.

6.1.3

Variation to the minimum site area requirements

- P3.1 The WAPC may approve the creation of a lot, survey strata lot or strata lot of a lesser minimum and/or average site area than that specified in table 1, and the WAPC or a council may approve the creation of a survey strata lot or strata lot for a single house or a grouped dwelling of a lesser minimum site area than that specified in table 1 provided that the proposed variation would meet the following criteria:
- be no more than five per cent less in area than that specified in table 1; and
 - facilitate the protection of an environmental or heritage feature; or
 - facilitate the retention of a significant element that contributes toward an existing streetscape worthy of retention; or
 - facilitate the development of lots with separate and sufficient frontage to more than one public street; or
- A3 Subject to 6.1.2 only, the following variations to the minimum and average site areas set out in table 1 may be made:
- i for the purposes of an aged or dependent persons' dwelling or a single bedroom dwelling, the minimum site area may be reduced by up to one third, in accordance with part 7.1.2 and 7.1.3; or
 - ii in the case of a single house, grouped dwelling or multiple dwelling; the area of a lot, survey strata lot or strata lot approved by the WAPC; or
 - iii the area of any existing lot, survey strata lot or strata lot with permanent legal access to a public road, notwithstanding that it is less than that required in table 1; or
 - iv in the case of grouped dwellings in areas coded R20 as at 4 October 2002, the average site area shall be 450 sq m where applications are made prior to and including 30 April 2009.

- overcome a special or unusual limitation on the development of the land imposed by its size, shape or other feature; or
- allow land to be developed with housing of the same type and form as land in the vicinity and which would not otherwise be able to be developed; or
- achieve specific objectives of the local government's scheme and, where applicable, the local planning strategy.

P3.2 The WAPC or a council may approve the creation of a survey strata lot or strata lot for an existing authorised grouped dwelling or multiple dwelling development of a lesser minimum and average site area than that specified in table 1, where, in the opinion of the WAPC or the council, the development on the resulting survey strata or strata lots is consistent with the objectives of the relevant design elements of the codes, and the orderly and proper planning of the locality.

6.2 Streetscape requirements

Objective

To contribute towards attractive streetscapes and security for occupants and passers-by, ensure adequate privacy and open space for occupants, and provide an attractive setting for buildings.

Performance criteria	Acceptable development
<p><i>New development should meet these criteria.</i></p>	<p><i>The acceptable development provisions illustrate one way of meeting the associated performance criteria.</i></p> <p>Note: Unless the context indicates otherwise, references to 'street' in this element include any communal street, private street, right-of-way or other shared access way that provides the principal frontage to a dwelling but does not include an access leg to a single battleaxe lot.</p>

6.2.1

Setback of buildings generally

<p>P1 Buildings setback from street boundaries an appropriate distance to ensure they:</p> <ul style="list-style-type: none"> • contribute to the desired streetscape • provide adequate privacy and open space for dwellings; and • allow safety clearances for easements for essential service corridors. 	<p>A1.1 Buildings setback from the primary street in accordance with table 1; or</p> <ul style="list-style-type: none"> i corresponding to the average of the setback of existing dwellings on each side fronting the same street; or in accordance with figure 1a, reduced by up to 50 per cent provided that the area of any building, including a carport or garage, intruding into the setback area is compensated for by at least an equal area of contiguous open space between the setback line and line drawn parallel to it at twice the setback distance; or ii in the case of areas coded R15 or higher, where: <ul style="list-style-type: none"> • a grouped dwelling has its main frontage to a secondary street; • a single house results from subdivision of an original corner lot and has its frontage to the original secondary street; • a single house or grouped dwelling (where that grouped dwelling is not adjacent to the primary street), has its main frontage to a communal street, right-of-way or shared pedestrian or vehicle access way; or
--	--

- the street setback may be reduced to 2.5 m, or 1.5 m to a porch, verandah, balcony or the equivalent; and
- iii to provide for registered easements for essential services.

A1.2 Buildings setback from the secondary street in accordance with table 1.

6.2.2 Minor incursions into street setback area

- | | | | |
|----|--|----|---|
| P2 | Minor incursions and projections not to detract from the character of the streetscape. | A2 | <ul style="list-style-type: none"> i In accordance with figure 1b, a porch, balcony, verandah, chimney, or the equivalent may (subject to the Building Code of Australia) project not more than 1 m into the street setback area, provided that the total of such projections does not exceed 20 per cent of the frontage at any level. ii Any eaves not forming part of a porch, balcony or verandah to project not more than 1 m into the street setback area for the full width of the building. |
|----|--|----|---|

6.2.3 Setback of garages and carports

- | | | | |
|----|---|------|--|
| P3 | The setting back of carports and garages so as not to detract from the streetscape or appearance of dwellings, or obstruct views of dwellings from the street and vice versa. | A3.1 | Garages and carports located behind the primary street setback line. |
| | | A3.2 | Garages and carports built up to the boundary abutting a private street or right-of-way which is not the principal frontage for the dwelling, with maneuvering space of at least 6 m, located immediately in front of the opening to the garage or carport and permanently available. |
| | | A3.3 | Garages set back 1.5 m from a secondary street. |
| | | A3.4 | Carports within the street setback area, provided that the width of carport does not exceed 50 per cent of the frontage at the building line and the construction allows an unobstructed view between the dwelling and the street, right-of-way or equivalent. |
| | | A3.5 | Garages set back 4.5 m from the primary street. In accordance with figure 1c this may be reduced where the garage adjoins a dwelling, provided the garage is at least 0.5 m behind the dwelling alignment (excluding any porch, verandah or balcony) or set back 3 m where vehicles are parked parallel to the street alignment. |

6.2.4

Surveillance of the street

- | | | | |
|----|--|------|--|
| P4 | Buildings designed to provide for surveillance between dwellings and the street. | A4.1 | At least one habitable room window of the dwelling has a clear view of the street and the approach to the dwelling. |
| | | A4.2 | In the case of a dwelling on a battleaxe lot, at least one habitable room window of the dwelling has a clear view of the approach to the dwelling. |
-

6.2.5

Street walls and fences

- | | | | |
|----|--|----|---|
| P5 | Front walls and fences to promote surveillance and enhance streetscape, taking account of: <ul style="list-style-type: none">the need to provide protection from noise and headlight glare where roads are designated as primary or district distributors or integrator arterials; orthe need to provide screening to the front setback; orthe need to provide privacy to north facing outdoor living areas. | A5 | Front walls and fences within the primary street setback area that are visually permeable 1.2 m above natural ground level. |
|----|--|----|---|
-

6.2.6

Sight lines at vehicle access points and street corners

- | | | | |
|----|--|----|--|
| P6 | Walls or fences to primary or secondary streets, rights-of-way or communal streets so that adequate sight lines are provided at vehicle access points. | A6 | Walls and fences truncated or reduced to no higher than 0.75 m within 1.5 m of where walls and fences adjoin vehicle access points where a driveway meets a public street and where two streets intersect. |
|----|--|----|--|
-

6.2.7

Building design

- | | | | |
|----|---|----|---|
| P7 | Buildings designed to enhance an existing desired streetscape, where the council has identified the need for design controls. | A7 | Buildings that comply with the provisions of a special control area, with the provisions of a local planning policy made under the scheme or with the provisions of the scheme, in respect of the design of carports and garages, the colour, scale, materials and roof pitch of buildings including outbuildings, the form and materials of retaining walls and the extent to which the upper levels of buildings as viewed from the street should be limited. |
|----|---|----|---|
-

6.2.8

Garage doors

- | | | | |
|----|---|----|---|
| P8 | The extent of frontage and building façade occupied by garages assessed against the need to maintain a desired streetscape not dominated by garage doors. | A8 | Where a garage is located in front or within 1 m of the building, a garage door and its supporting structures (or garage wall where a garage is aligned parallel to the street) facing the primary street are not to occupy more than 50 per cent of the frontage at the setback line as viewed from the street. This may be increased to 60 per cent where an upper floor or balcony extends for the full width of the garage and the entrance to the dwelling is clearly visible from the primary street. |
|----|---|----|---|
-

6.2.9

Appearance of retained dwelling

- | | | | |
|----|--|----|--|
| P9 | Enhancing the streetscape appearance of existing dwellings retained as part of a grouped dwelling development. | A9 | Where an existing dwelling is retained as part of a grouped dwelling development, the dwelling appearance is upgraded externally to an equivalent maintenance standard to the rest of the development. |
|----|--|----|--|
-

6.3 Boundary set-back requirements

Objective

To ensure adequate provision of direct sun and ventilation for buildings and to ameliorate the impacts of building bulk, interference with privacy, and overshadowing on adjoining properties.

Performance criteria	Acceptable development
<i>New development should meet these criteria</i>	<i>The acceptable development provisions illustrate one way of meeting the associated performance criteria.</i>

6.3.1 Buildings setback from the boundary

<p>P1 Buildings setback from boundaries other than street boundaries so as to:</p> <ul style="list-style-type: none"> • provide adequate direct sun and ventilation to the building; • ensure adequate direct sun and ventilation being available to adjoining properties; • provide adequate direct sun to the building and appurtenant open spaces; • assist with protection of access to direct sun for adjoining properties; • assist in ameliorating the impacts of building bulk on adjoining properties; and • assist in protecting privacy between adjoining properties. 	<p>A1 Buildings which are setback in accordance with the following provisions, subject to any additional measures in other elements of the codes:</p> <ul style="list-style-type: none"> i Buildings setback from boundaries other than street boundaries in accordance with table 1, tables 2a and 2b (for wall heights 10 m and less), figures 2a - 2e, and figure 3 (for wall heights in excess of 10 m). ii Unenclosed balconies, terraces, verandahs, and other areas accessible for use as outdoor living areas, whether roofed or not, if elevated 0.5 m or more above natural ground level, setback as though they were major openings to habitable rooms with a wall height of 2.4 m above their floor level. iii Separate single, multiple or grouped dwelling buildings on the same site, or facing portions of the same multiple dwelling building, setback from each other as though there were a boundary between them. iv Minor projections such as a chimney, other architectural feature or an eaves overhang not projecting more than 0.75 m into a set-back area and to be no closer than 0.75 m to a boundary. v The stated setback distances may be reduced by half the width of an adjoining right-of-way, pedestrian access way or battleaxe access leg, to a maximum reduction of 2 m.
--	---

Boundary walls – notes

- i The term 'up to a boundary' means either on the boundary or between the boundary and the setback provided by table 1, tables 2a and 2b, figures 2a - 2e, and figure 3.
- ii Where the subject site and an affected adjoining site are subject to different R-Codes, the length and height of the boundary wall on either site is determined by reference to the lower density code.

6.3.2

Buildings on boundary

<p>P2 Buildings built up to boundaries other than the street boundary where it is desirable to do so in order to:</p> <ul style="list-style-type: none"> • make effective use of space; or • enhance privacy; or • otherwise enhance the amenity of the development; • not have any significant adverse effect on the amenity of the adjoining property; and • ensure that direct sun to major openings to habitable rooms and outdoor living areas of adjoining properties is not restricted. 	<p>A2 Except where otherwise provided for in an adopted local planning policy, walls built up to a boundary behind the front setback line within the following limits, subject to the overshadowing provisions of design element 6.9:</p> <ul style="list-style-type: none"> i Where the wall abuts an existing or simultaneously constructed wall of similar or greater dimension; or ii In areas coded R20 and R25, walls not higher than 3 m with an average of 2.7 m up to 9 m in length up to one side boundary only; or iii In areas coded R30 and higher, walls not higher than 3.5 m with an average of 3 m for two-thirds the length of the balance of the boundary behind the front setback, to one side boundary only; or iv Where a detailed area plan applies to the land; or v Where both the subject site and the affected adjoining site are created in a plan of subdivision submitted concurrently with the development application; or vi In areas coded R-IC: <ul style="list-style-type: none"> a walls not higher than 3.5 m - no limit in length; b walls not higher than 6.5 m - two-thirds of the length of the boundary or 12 m, whichever is less.
---	--

6.3.3

Setback of retaining walls

<p>P3 Retaining walls designed or setback to minimise the impact on adjoining properties.</p>	<p>A3 Retaining walls setback from common boundaries in accordance with the setback provisions of table 1, tables 2a and 2b, and figure 3.</p>
---	--

6.4 Open space requirements

Objective

To ensure that private and communal open space is set aside and landscaped to provide for attractive streetscapes, attractive settings to complement buildings, privacy, direct sun, and the recreational needs of residents.

Performance criteria	Acceptable development
<i>New development should meet these criteria</i>	<i>The acceptable development provisions illustrate one way of meeting the associated performance criteria.</i>

6.4.1 Open space provision

P1	Sufficient open space around buildings <ul style="list-style-type: none"> to complement the building; to allow attractive streetscapes; to suit the future needs of residents, having regard to the type and density of the dwelling. 	A1	Open space provided in accordance with table 1 and design elements 6.2 and 6.3. The site of the grouped dwelling, for the purpose of calculating the open space requirement, shall include the area allocated for the exclusive use of that dwelling and the proportionate share of any associated common property.
----	--	----	---

6.4.2 Outdoor living areas

P2.1	An outdoor living area capable of use in conjunction with a habitable room of the dwelling, and if possible, open to winter sun.	A2	An outdoor living area to be provided: <ul style="list-style-type: none"> in accordance with table 1; behind the street set-back area; directly accessible from a habitable room of the dwelling; with a minimum length and width dimension of 4 m, except in areas coded R-IC where the minimum dimension may be 3 m; and to have at least two-thirds of the required area without permanent roof cover.
P2.2	An outdoor area that takes the best advantage of the northern aspect of the site.		

6.4.3 Balconies for multiple dwellings

P3	Balconies or equivalent outdoor areas which provide open space appurtenant to the dwelling.	A3	Each multiple dwelling is provided with at least one balcony or the equivalent, opening directly from a habitable room and with a minimum dimension of 2 m and a minimum area of 10 sq m.
----	---	----	---

6.4.4

Communal open space

- | | |
|--|--|
| <p>P4.1 Adequate area of communal open space for multiple dwelling developments to meet the future needs of residents, having regard to the location of the development.</p> <p>P4.2 Where desired by the proponent, communal open space is provided for a group of grouped dwellings.</p> | <p>A4.1 Communal open space for multiple dwellings provided in accordance with table 1.</p> <p>A4.2 Where communal open space is provided as common property in a grouped dwelling development, the open space required for any grouped dwelling having legal and direct physical access to that open space may be reduced by up to 20 per cent of the required open space area provided that:</p> <ul style="list-style-type: none"> • the aggregate of deducted area does not exceed the area of communal open space; and • the outdoor living area for any dwelling is not reduced in area. |
|--|--|

6.4.5

Landscaping requirements

- | | |
|--|---|
| <p>P5 All grouped and multiple dwelling common property areas and communal open spaces* are fully developed with appropriate planting, paving and other landscaping that:</p> <ul style="list-style-type: none"> • meets the projected needs of the residents; • enhances security and safety for residents; • retains significant existing trees; and • contributes to the streetscape. <p>*Note:
In the case of communal open spaces that are part of a subdivision development under green title or survey strata title, P5 and A5 are guidelines.</p> | <p>A5 Landscaping of grouped and multiple dwelling common property and communal open spaces in accordance with the following:</p> <ol style="list-style-type: none"> i the street setback area developed without car parking, except for visitors' bays, and with a maximum of 50 per cent hard surface; ii separate pedestrian paths providing wheelchair accessibility connecting all entries to buildings with the public footpath and car parking areas; iii landscaping between each six consecutive parking spaces; iv lighting to pathways, and communal open space and car parking areas; v bin storage areas conveniently located and screened from view; vi retention in open space of existing trees which are greater than 3 m in height; vii adequate sight lines for pedestrians and vehicles; viii clear line of sight between areas designated as communal open space and at least two habitable room windows; ix clothes drying areas which are secure and screened from view; and x unroofed visitors' parking bays to be effectively screened. |
|--|---|

6.5 Access and parking requirements

Objective

To ensure adequate provision of secure, visually acceptable and accessible on-site parking for residents and visitors.

Performance criteria	Acceptable development
<i>New development should meet these criteria</i>	<i>The acceptable development provisions illustrate one way of meeting the associated performance criteria.</i>

6.5.1

On-site parking provision

<p>P1 Adequate car parking provided on-site in accordance with projected need related to:</p> <ul style="list-style-type: none"> • the type, number and size of dwellings; • the availability of on-street and other off-street parking; • the location of the proposed development to public transport and other facilities. 	<p>A1 On-site parking spaces provided in accordance with the following:</p> <p>i Single houses:</p> <ul style="list-style-type: none"> • two spaces, which may be in tandem; or • where ancillary accommodation is provided – three spaces, two of which may be in tandem; or • in the case of a single bedroom dwelling of not more than 60 sq m floor area or aged or dependent persons' dwelling of not more than 100 sq m floor area – one space; or • in the case of a single house of not more than 120 sq m floor area on a site coded R-IC – one space, or as provided in a local planning policy. <p>ii Grouped dwellings:</p> <ul style="list-style-type: none"> • two spaces per dwelling; and at least one space provided for the exclusive use of each dwelling and where two spaces are so allocated they may be in tandem; or • in the case of a single bedroom dwelling of not more than 60 sq m plot ratio area or an aged or dependent persons' dwelling of not more than 100 sq m of plot ratio area – one space; and • in addition, visitors parking spaces are provided at a rate of one space for each four dwellings, or part thereof in excess of four dwellings, served by a common access. • in the case of a site coded R-IC – one space, or as provided in a local planning policy.
--	---

iii Multiple dwellings

- 0.35 spaces per dwelling plus 0.015 spaces per sq m of plot ratio area, to a maximum of two spaces per dwelling; and
- at least one space per dwelling provided for the exclusive use of each dwelling and where two or more spaces are provided, two may be in tandem; or
- in the case of single bedroom dwelling of not more than 60 sq m of plot ratio area or aged or dependent persons' dwellings of not more than 80 sq m of plot ratio area – 0.75 spaces per dwelling; or
- in the case of a site coded R-IC the total number of spaces reduced by one third, or as provided in a local planning policy; and
- not less than 10 per cent of the required spaces provided for exclusive use of visitors where more than four dwellings are provided.

6.5.2
Off-site parking

- P2.1 Some required spaces located off-site taking into account:
- i The parking area being sufficiently close to ensure its use by residents of the dwellings or visitors.
 - ii Any increase in numbers of dwellings or possible floorspace thereby being matched by an accompanying increase in aggregate number of parking spaces.
 - iii Permanent legal right of access being granted to all users and occupiers of dwellings for which the parking space is to be provided.
 - iv Where off-site parking is shared with other uses, the total aggregate parking requirement for all such uses, as required by the codes and the scheme being provided. The number of required spaces reduced by up to 15 per cent where the non-residential parking occurs substantially between 9 am and 5 pm on weekdays only.
- P2.2 Where street parking is controlled by the council during normal business hours, car parking provided for multiple developments being reduced in accordance with the number of on-street spaces assessed as being available to the development.

- A2.1 Some or all of the required parking spaces may, with the approval of council in accordance with the performance criteria, be located off-site.

6.5.3

Design of parking spaces

- P3 Car parking facilities designed and located to be convenient, secure, safe in use and consistent with streetscape objectives.
- A3.1 Visitors spaces:
- clearly marked as such, located close to and clearly signposted or visible from the point of entry to the development and outside any security barrier; and
 - providing a barrier-free path of travel for people with disabilities.
- A3.2 Spaces in accordance with AS2890.1.
- A3.3 In the case of multiple dwelling developments of 12 or more dwellings, all spaces except visitors' spaces fully concealed from the street or public place.
- A3.4 Car parking areas with six or more spaces to be provided with landscape planting in accordance with A5 of design element 6.4.

6.5.4

Vehicular access

- P4 Vehicular access provided so as to minimise the number of crossovers, avoid street trees, to be safe in use and not detract from the streetscape.
- A4.1 Access to on-site parking to be provided, where available, solely from a right-of-way available for use of the relevant lot and adequately formed and drained from the property boundary to a constructed street, or from a secondary street where a right-of-way does not exist.
- A4.2 Primary or secondary street formed driveways, where their provision is necessary, are limited as follows:
- driveways serving four dwellings or less not narrower than 3 m at the street frontage boundary;
 - subject to a minimum driveway width of 3 m at the street frontage boundary, driveways not to occupy more than 40 per cent of the frontage of a property, excluding any part of that frontage required for an access leg to a battleaxe lot;
 - no single driveways wider than 6 m at the street frontage boundary and driveways in aggregate no greater than 9 m for any one property.
- A4.3 Formed driveways:
- no closer than 0.5 m to a side lot boundary or street pole;
 - no closer than 6 m to a street corner or the point at which a carriageway begins to deviate;
 - aligned at right angles to the street alignment;

- located so as to avoid street trees, or, where this is unavoidable, the street trees replaced by the council at the applicant's expense or re-planting arrangements to be approved by the council.

A4.4 Formed driveways designed for two way access and for vehicles to enter the street in forward gear where:

- the driveway serves five or more dwellings; or
- the distance from a car space to street alignment is 15 m or more; or
- the public street to which it connects is designated as a primary distributor, district distributor or integrated arterial road.

A4.5 Formed driveways for multiple and grouped dwellings:

- with a minimum width of 4 m where the number of dwellings served is five or more, which may be reduced to 3 m where necessary to retain an existing dwelling; and
- are designed to allow vehicles to pass in opposite directions at one or more points, where the number of dwellings served by the driveway is five or more.

6.5.5 Pedestrian access

P5 Provision of safe and comfortable access for pedestrians between communal car parking areas or public streets and individual dwellings.

A5.1 Where a communal access way between a public street or a communal car parking area and individual dwellings serves 10 or more dwellings, there is a pedestrian path separate from vehicular access, designed according to (AS 1428.1, 2001) on access, to be barrier free and at least 1.2 m in width.

A5.2 Where a communal access way serving more than two dwellings is shared by pedestrians and vehicles, the access way is aligned to provide clear sight lines and is provided with adequate lighting to ensure pedestrian safety.

A5.3 A communal access way to be no closer than 3 m to a wall with a major opening unless screened.

State Planning Policy 3.1

Residential Design Codes (Variation 1)

- A5.4 Where multiple dwellings are served by stairs only, stairs are provided so that for normal access purposes no more than two dwellings at each floor level are served by each staircase.
 - A5.5 Access above ground level to all multiple dwellings is totally protected from weather.
-

6.6 Site works requirements

Objective

To preserve the sense of the natural topography of the site and locality with a view to the protection of streetscape and the amenity of adjoining properties.

Performance criteria	Acceptable development
<i>New development should meet these criteria.</i>	<i>The acceptable development provisions illustrate one way of meeting the associated performance criteria.</i>
6.6.1 Excavation or fill	
P1 Development that retains the visual impression of the natural level of a site, as seen from the street or other public place, or from an adjoining property.	<p>A1.1 Excavation or filling between the street alignment and building, or within 3 m of the street alignment, whichever is the lesser, not exceeding 0.5 m, except where necessary to provide access for pedestrians or vehicles, or natural light for a dwelling.</p> <p>A1.2 Excavation or filling within the perimeter of the external walls of a building, limited only by compliance with building height limits.</p> <p>A1.3 Excavation within a site and behind a street setback line shall have no limit.</p> <p>A1.4 Subject to A1.2, filling behind a street setback line and within 1 m of a common boundary not more than 0.5 m above the natural level at the boundary except where otherwise stated in a local planning policy or equivalent.</p>

6.7 Building height requirements

Objective

To ensure that the height of buildings is consistent with the desired scale in a given locality.

Performance criteria

New development should meet these criteria.

Acceptable development

The acceptable development provisions illustrate one way of meeting the associated performance criteria.

6.7.1

Building height

P1 Building height consistent with the desired height of buildings in the locality, and to recognise the need to protect the amenities of adjoining properties, including, where appropriate:

- adequate direct sun to buildings and appurtenant open spaces;
- adequate daylight to major openings to habitable rooms; and
- access to views of significance.

A1.1 Buildings which comply with table 3 for category B area buildings, except where stated otherwise in a local planning policy or equivalent.

6.8 Privacy requirements

Objective

To site and design buildings to meet projected user requirements for visual privacy and to minimise the impact of development on the visual privacy of adjoining residents in their dwellings and private open space.

Performance criteria	Acceptable development
<p><i>New development should meet these criteria.</i></p>	<p><i>The acceptable development provisions illustrate one way of meeting the associated performance criteria.</i></p> <p>Notes:</p> <ul style="list-style-type: none"> i Line of sight setback distances shall be measured by application of the cone of vision set out in the explanatory guidelines. ii Line of sight setback distances include the width of any adjoining right-of-way, communal street or battleaxe leg or the like. iii These provisions apply only where the adjoining affected land is zoned to allow for residential development.

6.8.1 Visual privacy

<p>P1 Direct overlooking of active habitable spaces and outdoor living areas of other dwellings is minimised by building layout, location and design of major openings and outdoor active habitable spaces, screening devices and landscape, or remoteness.</p> <p>Effective location of major openings and outdoor active habitable spaces to avoid overlooking is preferred to the use of screening devices or obscured glass.</p> <p>Where these are used, they should be integrated with the building design and have minimal impact on residents' or neighbours' amenity.</p> <p>Where opposite windows are offset from the edge of one window to the edge of another, the distance of the offset should be sufficient to limit views into adjacent windows.</p>	<p>A1 Major openings and unenclosed outdoor active habitable spaces (balconies, verandahs, terraces or other outdoor living areas) which have a floor level more than 0.5 m above natural ground level and which overlook any part of any other residential property behind its street setback line, to comply with the following:</p> <ul style="list-style-type: none"> i Are setback, in direct line of sight within the cone of vision, from the boundary a minimum of: <ul style="list-style-type: none"> • 4.5 m in the case of bedrooms and studies; • 6 m in the case of habitable rooms other than bedrooms and studies; and • 7.5 m in the case of unenclosed outdoor active habitable spaces; or ii Are provided with permanent vertical screening to restrict views within the cone of vision from any major opening of an active habitable space; or iii Are provided with permanent vertical screening or equivalent, preventing direct
--	---

State Planning Policy 3.1

Residential Design Codes (Variation 1)

line of sight within the cone of vision to ground level of the adjoining property if closer than 25 m to the opening or equivalent.

- A2 In multiple dwelling developments, major openings and unenclosed outdoor active habitable spaces within the cone of vision of an upper-level dwelling shall not overlook more than 50 per cent of the outdoor living area of a lower-level dwelling directly below and within the same development.
-

6.9 Design for climate requirements

Objective

To optimise comfortable living and facilitate sustainable development.

Performance criteria	Acceptable development
<i>New development should meet these criteria.</i>	<i>The acceptable development provisions illustrate one way of meeting the associated performance criteria.</i>

6.9.1 Solar access for adjoining sites

<p>P1 Development designed to protect solar access for neighbouring properties taking account the potential to overshadow:</p> <ul style="list-style-type: none"> • outdoor living areas; • major openings to habitable rooms; • solar collectors; or • balconies or verandahs. 	<p>A1 Notwithstanding the boundary setbacks in design element 6.3, development in climatic zones 4, 5 and 6 of the state shall be so designed that its shadow only cast at midday 21 June onto any other adjoining property does not exceed the following limits:</p> <ul style="list-style-type: none"> • on adjoining properties coded R25 and lower – 25 per cent of the site area; • on adjoining properties coded R30 to R40 inclusive – 35 per cent of the site area; or • on adjoining properties coded R-IC or higher than R40 – 50 per cent of the site area.
---	---

Note:

In this context site area refers to the surface of the adjoining lot and is measured without regard to any building on it but taking into account its natural ground levels.

6.9.2 Stormwater disposal

<p>P2 Stormwater contained within the site whenever possible.</p>	<p>A2 All water draining from roofs and other impermeable surfaces shall be directed to garden areas, sumps or rainwater tanks within the development site where climatic and soil conditions allow for the effective retention of stormwater on-site.</p>
---	--

6.10 Incidental development requirements

Objective

To ensure that (a) outbuildings and fixtures attached to buildings do not detract from the streetscape, or the amenity of the development or that of adjoining residents; and (b) adequate provision is made for incidental facilities serving residents' needs.

Performance criteria	Acceptable development
<i>New development should meet these criteria.</i>	<i>The acceptable development provisions illustrate one way of meeting the associated performance criteria.</i>

6.10.1 Outbuildings

P1	Outbuildings that do not detract from the streetscape or the visual amenity of residents or neighbouring properties.	A1	Outbuildings that: <ul style="list-style-type: none"> i are not attached to a dwelling; ii are non-habitable; iii collectively do not exceed 60 sq m in area or 10 per cent in aggregate of the site area, whichever is the lesser; iv do not exceed a wall height of 2.4 m; v do not exceed ridge height of 4.2 m; vi are not within the primary street setback area; vii do not reduce the amount of open space required in table 1; and viii comply with the siting and design requirements for the dwelling, but do not need to meet rear setback requirements of table 1.
----	--	----	--

6.10.2 External fixtures

P2	Solar collectors permitted as of right and other external fixtures that do not detract from the streetscape or the visual amenity of residents or neighbouring properties.	A2.1	The location of solar collectors attached to or emerging from buildings is permitted as of right as primacy must be given to maximising the efficiency of these units.
		A2.2	Television aerials of the standard type, essential plumbing vent pipes above the roof line and external roof water down pipes.
		A2.3	Other external fixtures that: <ul style="list-style-type: none"> i are not visible from the primary street; ii are designed integrally with the building; or iii are located so as not to be visually obtrusive.
		A2.4	Antennae, satellite dishes and the like not visible from the street.

6.10.3 Essential facilities

- P3 Provision made for external storage, rubbish collection/storage areas, and clothes-drying areas that are:
- adequate for the needs of residents; and
 - without detriment to the amenity of the locality.
- A3.1 An enclosed, lockable storage area, constructed in a design and material matching the dwelling where visible from the street, accessible from outside the dwelling, with a minimum dimension of 1.5 m with an internal area of at least 4 sq m, for each grouped or multiple dwelling.
- A3.2 Where rubbish bins are not collected from the street immediately adjoining a dwelling, there is provision of a communal pick-up area or areas which are:
- i conveniently located for rubbish and recycling pick-up;
 - ii accessible to residents;
 - iii adequate in area; and
 - iv fully screened from view from the primary or secondary street.
- A3.3 Single houses and grouped dwellings provided with an adequate clothes-drying area appurtenant to each dwelling, screened from view from the primary or secondary street.
- A3.4 Multiple dwelling developments:
- provided with an adequate common area set aside for clothes-drying, screened from view from the primary or secondary street; or
 - clothes drying facilities excluding electric clothes dryers screened from public view provided for each multiple dwelling.
-



State Planning Policy 3.1

Residential Design Codes (Variation 1)

State Planning Policy 3.1

Residential Design Codes

(Variation 1)

R Codes

Part 7 - Special provisions

- 7.1 Special purpose dwellings requirements
- 7.2 Mixed use development requirements
- 7.3 Inner city housing requirements



State Planning Policy 3.1

Residential Design Codes (Variation 1)

Part 7 - Special provisions

7.1 Special purpose dwellings requirements

Objective

To ensure that dwellings for the aged and for people with special needs can be provided within normal residential areas.

Performance criteria	Acceptable development
<i>New development should meet these criteria.</i>	<i>The acceptable development provisions illustrate one way of meeting the associated performance criteria.</i>

7.1.1

Ancillary accommodation

<p>P1 Ancillary dwellings that accommodate the needs of large or extended families without compromising the amenity of adjoining properties.</p>	<p>A1 An additional dwelling or independent accommodation associated with a single house and on the same lot where:</p> <ul style="list-style-type: none"> i the sole occupant or occupants are members of the family of the occupiers of the main dwelling; ii the lot is not less than 450 sq m in area; iii the open space requirements of table 1 are met; iv there is a maximum floor area of 60 sq m; and iv one additional car space is provided.
--	---

7.1.2

Aged or dependent persons' dwellings

<p>P2 Dwellings that accommodate the special needs of aged or dependent persons and which:</p> <ul style="list-style-type: none"> • are designed to meet the needs of aged or dependent persons; • are located in proximity to public transport and convenience shopping; • have due regard to the topography of the locality in which the site is located; and • satisfy a demand for aged or dependent persons' accommodation. 	<p>A2 Dwellings for the housing of aged or dependent persons that comply with the following:</p> <ul style="list-style-type: none"> i A maximum plot ratio area of: <ul style="list-style-type: none"> • in the case of single houses or grouped dwellings – 100 sq m; or • in the case of multiple dwellings – 80 sq m. ii A minimum number of five dwellings within any single development. iii All ground floor units, with a preference for all dwellings, to incorporate, as a minimum, the following. <ul style="list-style-type: none"> • an accessible path of travel from the street frontage, car parking area or
--	---

- drop-off point in accordance with the requirements of AS4299:1995 clause 3.3.2;
 - level entry to the front entry door with preferably all external doors having level entries (diagrams, figure C1 of AS4299:1995).
- iv All dwellings to incorporate, as a minimum, the following:
- all external and internal doors to provide a minimum 820 mm clear opening. (AS4299:1995 clause 4.3.3);
 - internal corridors to be a minimum 1000 mm wide, width to be increased to a minimum of 1200 mm in corridors with openings on side walls;
 - a visitable toilet (AS4299:1995, clause 1.4.12), preferably located within a bathroom;
 - toilet and toilet approach doors shall have a minimum 250 mm nib wall on the door handle side of the door and provision for the installation of grab rails in accordance with AS4299:1995, clause 4.4.4 (h).
- v Visitors car spaces at the rate of one per four dwellings, with a minimum of one space.
- vi The first visitors car space shall provide a wheelchair accessible parking space and be a minimum width of 3.8 m in accordance with AS4299:1995, clause 3.7.1.
- vii At least one occupant is a disabled or physically dependent person or aged over 55, or is the surviving spouse of such a person, and the owner of the land agrees to enter into a legal agreement, binding the owner, their heirs and successors in title requiring that this provision be maintained.
- viii Provide an outdoor living area in accordance with the requirements of clause 6.4.2 but having due regard to a one third reduction in the area specified in table 1.

7.1.3

Single bedroom dwellings

P3	Dwellings that provide limited accommodation, suitable for one or two persons.	A3	Single bedroom dwellings with a maximum plot ratio area of 60 sq m.
----	--	----	---

7.2 Mixed use development requirements

Objective

To ensure that a reasonable standard of residential amenity is maintained for dwellings that are provided in conjunction with commercial or other non-residential uses.

Performance criteria	Acceptable development
<i>New development should meet these criteria.</i>	<i>The acceptable development provisions illustrate one way of meeting the associated performance criteria.</i>

7.2.1

Dwellings in mixed use developments

<p>P1 Dwellings combined with non-residential uses on the same site that provide comparable standards of amenity to other multiple dwellings taking account of the need to:</p> <ul style="list-style-type: none"> • satisfy streetscape objectives; • provide open space in accordance with resident needs; and • provide car parking to satisfy reciprocal requirements of residents and other users. 	<p>A1 The dwelling component of a mixed use building developed in accordance with:</p> <ol style="list-style-type: none"> i the relevant provisions, if any, of the scheme; or ii where multiple dwellings are permissible under the scheme but no R-Codes is designated for the site, in accordance with the multiple dwelling requirements of the R60 code; and iii to the extent that the scheme allows, subject to the following: <ul style="list-style-type: none"> • minimum street setbacks - nil; • other boundary setbacks - as in table 1; • walls on the boundary for two-thirds of the boundary behind the street setback up to 6 m height; • on-site car parking - as for multiple dwellings; may be reduced to one per dwelling where on-site parking required for other users is available outside normal business hours; • open spaces generally - nil; • communal open space - nil; • outdoor living area - all dwellings required to have a balcony, or ground floor open space, not less than 1.5 m depth and a minimum area of 4 sq m; and • plot ratio - as provided in table 1, in addition to any ground level non-residential floor area.
--	---

7.3 Inner city housing requirements

Objective

To ensure that residential development in the inner city areas coded R-IC occurs in ways that:

- are consistent with the density and built form for the predominant development of the locality;
- contribute positively to the streetscape of which they are part;
- contribute positively to street activity;
- are consistent with general car parking provisions and transport policies for the locality;
- provide high standards of amenity and on-site facilities for residents;
- encourage the conversion of existing buildings to residential use;
- encourage sustainable design principles; and
- encourage the conservation of heritage buildings and places.

Performance criteria	Acceptable development
<i>New development should meet these criteria.</i>	<i>The acceptable development provisions illustrate one way of meeting the associated performance criteria.</i>
<h3>7.3.1 Housing density and built form</h3>	
P1.1 Consistency with the density and intensity of use desired for the locality generally, including other significant land uses.	A1 i Development of single houses, grouped dwellings, and multiple dwellings in accordance with table 1.
P1.2 Consistency with the height, bulk and space around buildings similar to those applying to commercial buildings in the precinct or locality.	ii Development of serviced apartments or other self-contained residential suites within a building such that the plot ratio of the building does not exceed 1.25, excluding any associated non-residential ground floor uses.
P1.3 Buildings converted from non-residential to residential use so as to ensure that basic safety and health of residents is not compromised.	

7.3.2 Streetscape

- P2.1 Buildings designed to:
- complement the desired character of the streetscape and locality or precinct;
 - face the street and other public spaces;
 - promote physical interaction between the building and pedestrians at street level;
 - minimise vehicle crossovers;
 - conceal on-site parking from view from the public domain;
 - have entrances on to the street; and
 - provide visual interest at the street face, especially at street level.
- P2.2 Buildings designed to provide surveillance of the public domain and communal spaces, and safe and well-lit access and entryways between dwellings and other uses, and the public domain.

7.3.3 Boundary setbacks

- P3 Buildings designed in the context of the common theme within in each street and/or street block in respect of side setbacks and the extent of boundary walls.
-

7.3.4 Open space

- P4 Open space provided in accordance with the needs of residents, for private and communal (recreational and social) purposes.
-

7.3.5 Access and car parking

- P5.1 Access to car parking that is safe, convenient and compatible with amenity of residents and pedestrians.
- P5.2 Car parking provision which is consistent with:
- car-parking policy and requirements for the precinct or locality generally;
 - the needs of residents;
 - the need to avoid adverse impact on traffic management and parking policy generally in the relevant precinct; and
 - policies relating to reciprocal car parking provision and the provision of off-site parking.
- P5.3 Provision of safe and comfortable access for pedestrians between communal car parking areas or public streets and individual dwellings, including:
- pedestrian access ways and vehicle access ways;
 - the extent of cover from the point of entry at the street face to each dwelling; and
 - adequate nocturnal lighting of pedestrian access ways.
-

7.3.6 Site levels

- P6 Development that retains the visual impression of the natural level of a site, as seen from the street or other public place, or from an adjoining property.

7.3.7

Height and bulk

- P7 Consistency with the height, bulk and general setback of buildings desired for the street and/or street block.
-

7.3.8

Privacy

- P8 Major openings and private balconies located so as to minimise overlooking of the indoor and outdoor living areas of adjoining properties.
-

7.3.9

Design for solar access

- P9 Provision of adequate direct sun to habitable rooms and open space on the development site and appropriate protection of solar access to adjoining sites and the public domain.
-

7.3.10

Incidental development

- P10 Appropriate facilities on site to meet the needs of residents, including provision of:
- convenient and visually screened areas for service access and bin storage and pick-up;
 - protected areas within or close to dwellings for private storage;
 - convenient positioning of mail boxes;
 - provision for clothes drying within dwellings or in secure, visually screened areas; and
 - communal meeting or recreation areas where appropriate.
-

State Planning Policy 3.1

Residential Design Codes

(Variation 1)

R Codes

Appendices

Appendix 1 - Definitions

Appendix 2 - Codes approval application form

Appendix 3 - Codes approval decision form

Appendix 4 - Adjoining property owner comment form
(discretionary approval application under
the Residential Design Codes)



State Planning Policy 3.1

Residential Design Codes (Variation 1)

Appendix 1 - Definitions

In the case of residential development under the codes, unless the context requires otherwise, words and expressions have the meaning given to them below.

Acceptable development

Development that complies with the corresponding provision for acceptable development in the codes unless council has a contrary local planning policy.

Active habitable space

Any habitable room with a floor area greater than 10 sq m and any balcony, verandah, terrace or other outdoor living area raised more than 0.5 m above natural ground level and greater than 1 m in dimension and 3 sq m in area.

Adjoining property

Any lot:

- on which any dwelling for which provision is made in the codes may be constructed under the scheme; and
- which shares a boundary or portion of a boundary with a lot on which there is a proposed residential development site or is separated from that lot by a right-of-way, vehicle access way, pedestrian access way, access leg of a battleaxe lot or the equivalent not more than 6 m in width.

Aged person

A person who is aged 55 years or over.

Ancillary accommodation

Self-contained living accommodation on the same lot as a single house that may be attached or detached from the single house occupied by members of the same family as the occupiers of the main dwelling.

Balcony

A balustraded platform on the outside of a dwelling with access from an upper internal room.

Battleaxe lot

A single house lot that has a frontage to a public road only through a pedestrian or vehicular access way that is part of the lot. The term excludes a site that has vehicle access from a private or communal street or right-of-way connected to a public road.

Building

Any structure whether fixed or moveable, temporary or permanent, placed or erected on land, and the term includes dwellings and structures appurtenant to dwellings such as carports, garages, verandahs, patios, outbuildings and retaining walls, but excludes boundary fences, pergolas and swimming pools.

Carport

A roofed structure designed to accommodate one or more motor vehicles unenclosed except to the extent that it abuts a dwelling or a property boundary on one side, and being without a door unless that door is visually permeable.

Common property

- So much of the land comprised in a strata plan as from time to time is not comprised in a lot shown on the plan.
- Any leasehold interest acquired by a strata company under section 18 of the *Strata Titles Act 1985*.
- The lot or lots shown on a survey strata plan as common property.

Communal open space

Open space set aside for the recreational use of the occupants of the dwellings in a common development and does not include driveways or car parking areas.

State Planning Policy 3.1

Residential Design Codes (Variation 1)

Communal street

A private carriageway providing joint access to two or more dwellings in a residential development.

Cone of vision

The limits of outlook from any given viewpoint for the purposes of assessing the extent of overlooking from that point illustrated in design element 6.8.

Council

The relevant local government or other body responsible for granting or refusing consent to development pursuant to a local planning scheme.

Dependent person

A person with a recognised form of disability requiring special accommodation for independent living or special care.

Development site

A parent lot in which development is proposed.

Detailed area plan

The design guidelines prepared for lots below 350 sq m and other lots as appropriate, which are adopted by a council under the structure plan provisions of its local planning scheme in order to vary the acceptable development provisions of the R-Codes, and may also address matters raised in element 3 - lot layout of Liveable Neighbourhoods or its replacement.

Dwelling

A building or portion of a building being used, adapted, or designed or intended to be used for the purpose of human habitation on a permanent basis by a single person, a single family, or no more than six persons who do not comprise a single family.

Effective lot area

The area of the lot, including any adjoining land that may be taken into account at clause 6.1.2 A2 in assessing compliance with the minimum site area requirements.

Formed driveway

The paved vehicle access way between the parking area of a dwelling and the property boundary, excluding any associated landscaping or pedestrian path on either side.

Frontage

The width of a lot at the primary street setback line, provided that in the case of battleaxe or other irregularly shaped lots, it shall be as determined by the council.

Garage

Any roofed structure, other than a carport, designed to accommodate one or more motor vehicles and attached to the dwelling.

Green title

A lot owned in fee simple issued with a certificate of title under the *Transfer of Land Act 1893* other than a strata lot or a survey strata lot.

Ground floor area

Any area that is not open space that has a floor area not more than 0.5 m above natural ground level.

Grouped dwelling

A dwelling that is one of a group of two or more dwellings on the same lot such that no dwelling is placed wholly or partly vertically above another, except where special conditions of landscape or topography dictate otherwise, and includes a dwelling on a survey strata with common property.

Habitable room

A room used for normal domestic activities that includes:

- a bedroom, living room, lounge room, music room, sitting room, television room, kitchen, dining room, sewing room, study, playroom, sunroom, gymnasium, fully enclosed swimming pool or patio; but excludes
- a bathroom, laundry, water closet, food storage pantry, walk-in wardrobe, corridor, hallway, lobby, photographic darkroom, clothes-drying room, verandah and unenclosed swimming pool or patio and other spaces of a specialised nature occupied neither frequently nor for extended periods.

Height, building

The vertical distance at any point from natural ground level to the uppermost part of the building above that point (roof ridge, parapet or wall), excluding minor projections above that point.

Height, wall

The vertical distance from natural ground level to the roof or parapet at any point in accordance with figures 2A, 2B and 2C.

Incidental development

Development which is associated with or attached to a dwelling and incidental to its main residential functions.

Inner city housing

Areas designated in the scheme as R-IC where the special provisions of the R-Codes apply.

Landscape, landscaping or landscaped

Land developed with garden beds, shrubs and trees, or by the planting of lawns, and includes such features as rockeries, ornamental ponds, swimming pools, barbecue areas or playgrounds and any other such area approved of by the council as landscaped area.

Local planning policy

Any policy prepared by a local government in accordance with the procedures set out in the Model Scheme Text or equivalent procedures in the scheme.

Lot

For single houses, a lot as defined under the *Planning and Development Act 2005*, and therefore for multiple or grouped dwellings, the parent lot, inclusive of common areas, on which the strata scheme relates as defined under the *Planning and Development Act 2005*.

Major opening

A window, door or other opening in the exterior wall of a habitable room that provides external means of light or view for that room or space, but does not include an opening or openings that:

- in aggregate do not exceed 1 sq m in any such wall, (provided that adjoining or contiguous windows at the junction of two walls forming an internal angle of 90 degrees or less shall be aggregated); or
- are glazed in an obscure material and are not able to be opened; or have a sill height not less than 1.6 m above floor level.

Minor projection

- In relation to the height of a building: a chimney, vent pipe, aerial or other appurtenance of like scale;
- In relation to a wall: a rainwater pipe, vent pipe, eaves overhang, cornice or other molding or decorative feature, provided that the projection does not exceed 0.75 m measured horizontally.

Mixed use development

Buildings that contain commercial and other non-residential uses in conjunction with residential dwellings in a multiple dwelling configuration.

Model Scheme Text

The framework for setting out local planning schemes as described in appendix B to the Town Planning Regulations 1967.

Multiple dwelling

A dwelling in a group of more than one dwelling on a lot where any part of a dwelling is vertically above part of any other but:

- does not include a grouped dwelling; and
- includes any dwellings above the ground floor in a mixed use development.

Natural ground level

The levels on a site which precede the proposed development, excluding any site works unless approved by the council or established as part of subdivision of the land preceding development.

Open space

Generally that area of a lot which is not occupied by any building and includes:

- open areas of accessible and useable flat roofs and outdoor living areas above natural ground level;
- areas beneath eaves overhangs, verandahs or patios not more than 0.5 m above natural ground level, unenclosed on at least two sides and covering no more than 10 per cent of the site area or 50 sq m whichever is the lesser;
- pergolas;
- uncovered driveways (including access aisles in parking areas) and uncovered car bays;

but excludes:

- non-accessible roofs, verandahs and balconies over 0.5 m above natural ground level;
- covered car parking bays and walkways, areas for rubbish disposal, stores, outbuildings or plant rooms.

Outdoor living area

The area external to a single house or grouped dwelling to be used in conjunction with that dwelling such that it is capable of active or passive use but excludes any area with a dimension of less than 1 m minimum dimension or which, by reason of its development or topography, is not readily accessible from the dwelling.

Outbuilding

An enclosed non-habitable structure that is detached from any dwelling.

Parent lot

A parent lot has the same meaning as a lot.

Patio

A water impermeable roofed open-sided area which may or may not be attached to a dwelling.

Performance criteria

Criteria to be used in the preparation, submission and assessment of development proposals for the purpose of determining their acceptability.

Pergola

An unroofed open-framed structure.

Plot ratio

The ratio of the gross total of all floors of buildings on a site to the area of land in the site boundaries. For this purpose, such areas shall include the area of any walls but not include the areas of any lift shafts, stairs or stair landings common to two or more dwellings, machinery, air conditioning and equipment rooms, non-habitable space that is wholly below natural ground level, areas used exclusively for the parking of wheeled vehicles at or below natural ground level, lobbies or amenities areas common to more than one dwelling, or balconies or verandahs open on at least two sides.

Plot ratio area

The floor area of buildings on a site as delineated in the definition of plot ratio.

Primary street

Unless otherwise designated by the local government, the sole or principal public road that provides access to the major entry (front door) to the dwelling.

Private open space

Open space set aside on a lot for the exclusive use of the occupants of the dwelling to which it abuts and excludes car parking spaces and access ways.

Residential building

A building or portion of a building, together with rooms and outbuildings separate from such building but incidental thereto; such building being used or intended, adapted or designed to be used for the purpose of human habitation:

- temporarily by two or more persons; or
- permanently by seven or more persons, who do not comprise a single family, but does not include a hospital or sanatorium, a prison, a hotel, a motel or a residential school.

Right-of-way

A laneway, private street, or other use of land (not being a public street or road) that provides vehicular access to a development site.

Scheme

The local planning scheme that specifies zoning and development standards gazetted pursuant to the *Planning and Development Act 2005*.

Screening

Permanently fixed external perforated panels or trellises composed of solid or obscured translucent panels.

Secondary street

In the case of a site that has access from more than one public road, a road that is not the primary street but which intersects with or adjoins that road.

Serviced apartment

A residential dwelling that forms part of a complex where common maintenance or other services are provided.

Setback

The horizontal distance between a wall at any point and an adjacent lot boundary, measured at right angles (90 degrees) to the boundary.

Single bedroom dwelling

A dwelling that contains a living room and no more than one other habitable room that is capable of use as a bedroom.

Single house

A dwelling standing wholly on its own green title or survey strata lot, together with any easement over adjoining land for support of a wall or for access or services and excludes dwellings on titles with areas held in common property.

Site

- In the case of a single house, the green title or survey strata lot on which it stands.
- In the case of a grouped dwelling, the area occupied by the dwelling together with any area allocated (whether by way of strata title or otherwise) for the exclusive use or benefit of that dwelling.
- In the case of a multiple dwelling development, the lot (or parent lot where the lot is subdivided under strata title) on which the dwellings stand.

State Planning Policy 3.1

Residential Design Codes (Variation 1)

Site area

The area of land required for the construction of a dwelling to satisfy the requirements of the codes.

Special control area

Land designated on the scheme map to which special controls apply.

Storey

That part of a building between floor levels. If there is no floor above, it is the part between the floor level and the ceiling.

Strata lot

One or more cubic spaces forming part of a lot in a strata scheme.

Strata plan

Has the meaning given by section 4 (1a) of the *Strata Titles Act 1985*.

Strata scheme

Has the meaning given under the *Strata Titles Act 1985*.

Street

Any public road, communal street, private street, right-of-way or other shared access way that provides the principal frontage to a dwelling but does not include an access leg to a single battleaxe lot.

Street setback

The horizontal distance between the street alignment and a building, measured at right angles (90 degrees) to the street alignment.

Street setback area

The area between the street alignment and the street setback line as set out in table 1 or as established in a particular case in accordance with the provisions of design element 6.2.

Street alignment

The boundary between the land comprising a street and the land that abuts thereon.

Survey strata

A lot and associated common property as shown on a registered survey-strata plan prepared in accordance with section 4 (1b) of the *Strata Titles Act 1985*.

Survey strata lot

Land that is shown as an ordinary lot consisting of two or more lots on a survey strata plan and does not include a lot shown as common property prepared in accordance with section 3 of the *Strata Titles Act 1985*.

Survey strata plan

A registered survey strata plan prepared in accordance with section 4 (1b) of the *Strata Titles Act 1985* and which shows the whole or any part of the land comprised in the plan as divided into two or more lots.

Survey strata scheme

The manner of division of the land comprised in a survey strata scheme into lots and common property and the manner of the allocation of unit entitlements, rights and obligations among the lots.

Tandem parking

Two parking spaces arranged one behind the other where parking in one bay precludes vehicular entry or exit to or from the other bay.

Verandah

A roofed open platform attached to a dwelling.

Visually permeable

In reference to a wall, gate, door or fence that the vertical surface has:

- continuous vertical or horizontal gaps of at least 50 mm width occupying not less than one third of its face in aggregate of the entire surface or where narrower than 50 mm, occupying at least one half of the face in aggregate, as viewed directly from the street; or
- a surface offering equal or lesser obstruction to view.

Wall

The vertical external face of a constructed building comprising solid building material and including enclosures to verandahs and balconies.

WAPC

The Western Australian Planning Commission.

Appendix 2 - Codes approval application form

Residential Design Codes
Application for single house and outbuilding codes approval

To: City/Town/Shire of:

Note: This is not an application for planning approval.
Application for single house and outbuilding approval is to be made on this form
if
an application for planning approval is not required under the local planning scheme
and
the proposed development involves one of the following:

- the exercise of a discretion by the council under the Residential Design Codes; or
- the exercise of a discretion by the council under a local planning policy made in accordance with the local planning scheme.

If you are in doubt about whether application should be made on this form, please consult the council's planning or building officers.

Owner details:

Name:

Address: Postcode:

Signature: Date:

Signature: Date:

All owners must sign this form or an attachment if there is not sufficient space. State your position where signing on behalf of a company. This application will not proceed otherwise.

Applicant details:

Name:

Address:

Contact person: Phone: Fax:

Email: Signature: Date:

Property details:

Lot no: House/street no:

Street name:

Suburb:

Location no: Diagram/plan no: Certificate of title no: Folio:

Nearest street intersection:

Title encumbrances (eg easements, restrictive covenants):

Approximate cost of proposed development:

Please fill in the details on the reverse

Appendix 3 - Codes approval decision form

Residential Design Codes
Notice of approval/refusal to codes approval application

Proposal:

Location:

Name of owner of land on which the development is proposed:

Surname/company name:

Other name(s):

Address:

Approval to commence development in accordance with the application for codes approval dated

and plans dated

is: Approved
 Approved subject to the following conditions
 Refused for the following reasons

Conditions/reasons for refusal:

Note: Should the applicant be aggrieved by this decision, a right of review may exist under the provisions of the *Planning and Development Act 2005*.

This approval is valid for a period of

If development is not commenced within this period a fresh approval must be obtained before commencing or continuing the development.

.....
Chief Executive Officer

.....
Date

Appendix 4 - Adjoining property owner comment form (discretionary approval application under the Residential Design Codes)

Residential Design Codes
Adjoining property owner comment on discretionary approval application

Adjoining property owner details

Name:

Lot no: Street no: Street name:

Suburb: Postcode:

Location of proposed development

Name:

Lot no: Street no: Street name:

Suburb: Postcode:

Details of matters on which council discretion is required and comment sought

Plan attached Details of proposed codes variations, or matters on which council discussion is required

Adjoining property owners comments

I/we have inspected the plans and comment as follows:

(Attach additional information and plans if necessary)

Signed: Date: Phone:

Print name:

Signed: Date: Phone:

Print name:

Note: The council in determining the application under the Residential Design Codes will take into account the comments of adjoining owners. The council is not obliged to support the views of adjoining owners.



State Planning Policy 3.1

Residential Design Codes (Variation 1)

State Planning Policy 3.1

Residential Design Codes

(Variation 1)

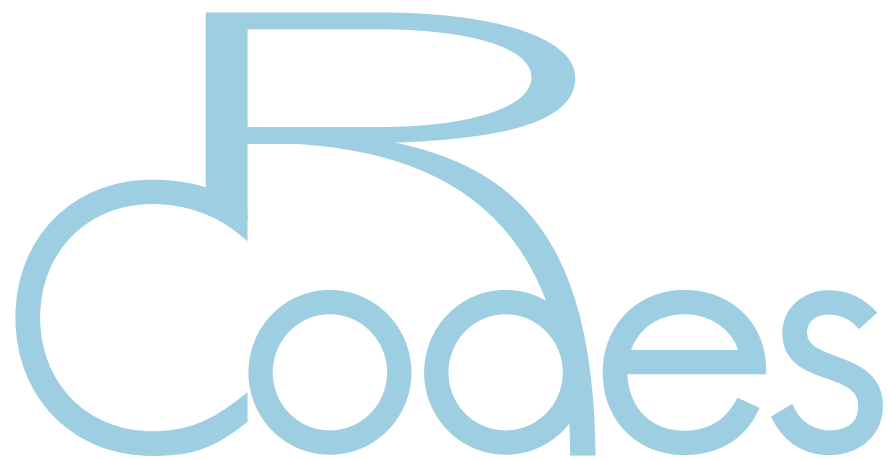
A large, light blue version of the 'R Codes' logo is centered on the page. It consists of a large, stylized 'R' with a white outline, followed by the word 'Codes' in a light blue, sans-serif font.

Tables

Table 1 - General site requirements

Table 2a and 2b - Boundary setbacks

Table 3 - Maximum building heights



State Planning Policy 3.1

Residential Design Codes (Variation 1)

Table 1 - General site requirements

1 R-Code	2 Dwelling type	3 Minimum site area per dwelling (m ²)◆	4 Minimum lot area/rear Battleaxe (m ²)▼	5 Maximum plot ratio	6 Minimum frontage (m)▼	7 Open Space			8 Minimum setbacks (m)			
						min total (% of site)	min communal (m ²)	min o/door living (m ²)	primary street	secondary street ●	other/rear	
Low Density Codes												
R2	Single house or grouped dwelling	Min 5000	-	-	50	80	-	-	20	10	10	
R2.5	Single house or grouped dwelling	Min 4000	-	-	40	80	-	-	15	7.5	7.5	
R5	Single house or grouped dwelling	Min 2000	-	-	30	70	-	-	12	6	*/6	
R10	Single house or grouped dwelling	Min 875 Av 1000	925	-	20	60	-	-	7.5	3	*/6	
	Multiple dwelling	1000	-	-	20	-	-	-	7.5	3	*/6	
R12.5	Single house or grouped dwelling	Min 700 Av 800	762.5	-	17	55	-	-	7.5	2	*/6	
	Multiple dwelling	800	-	-	20	-	-	-	7.5	2	*/6	
R15	Single house or grouped dwelling	Min 580 Av 666	655	-	12	50	-	-	6	1.5	*/6	
	Multiple dwelling	666	-	-	20	-	-	-	6	1.5	*/6	
R17.5	Single house or grouped dwelling	Min 500 Av 571	587.5	-	12	50	-	36	6	1.5	*	
	Multiple dwelling	571	-	-	20	-	-	-	6	1.5	*	
R20	Single house or grouped dwelling	Min 440 Av 500	540	-	10	50	-	30	6	1.5	*	
	Multiple dwelling	500	-	-	20	-	-	-	6	1.5	*	
R25	Single house or grouped dwelling	Min 320 Av 350	445	-	8	50	-	30	6	1.5	*	
	Multiple dwelling	400	-	-	20	-	-	-	6	1.5	*	
Medium Density Codes												
R30	Single House or grouped dwelling	Min 270 Av 300	420	-	-	45	-	24	4	1.5	*	
	Multiple dwelling	Min 333	-	-	20	-	-	-	4	1.5	*	
R35	Single house or grouped dwelling	Min 235 Av 260	410	-	-	45	-	24	4	1.5	*	
	Multiple dwelling	285	-	0.60	-	50	20	-	4	1.5	*	
R40	Single house or grouped dwelling	Min 200 Av 220	400	-	-	45	-	20	4	1.0	*	
	Multiple dwelling	250	-	0.60	-	50	20	-	4	1.5	*	
R50	Single house or Grouped dwelling	Min 160 Av 180	400	-	-	45	-	16	4	1.0	*	
	Multiple dwelling	200	-	0.60	-	50	16	-	4	1.0	*	
R60	Single house or Grouped dwelling	Min 160 Av 180	400	-	-	45	-	16	4	1.0	*	
	Multiple dwelling	166	-	0.70	-	50	16	-	4	1.0	*	
High Density Codes Note: All standards for grouped dwellings and single houses within R80-R160 areas are as for the R60 Code.												
R80	Multiple dwelling	125	-	1.00	-	60	16	-	4	*	*	
R100	Multiple dwelling	100	-	1.25	-	60	16	-	4	*	*	
R160	Multiple dwelling	62.5	-	2.00	-	60	16	-	4	*	*	
R-IC	Single house or grouped dwelling	110	-	1.25	-	35	-	12	1.5	*	*	
	Multiple dwelling	125	-	1.50	-	35	16	-	1.5	*	*	

Legend

- ◆ Subject to the variations permitted under clause 6.1.3 A3.
- ▼ Only applies to single houses.
- Secondary street: includes communal street, private street, right-of-way as street.

- Indicates not applicable.
- * See tables 2a and 2b and design element 6.3.
- Av. – average site area not to be less than.

Table 2a - Boundary setbacks

Walls with no major openings														
	Wall length (m)													
Wall height (m)	9 or less	10	11	12	13	14	15	16	17	18	19	20	25	Over 30
3.5 or less*	1	1.5	1.5	1.5	1.5	1.5	1.5	1.5	1.5	1.5	1.5	1.5	1.5	1.5
4.0	1.1	1.5	1.5	1.5	1.5	1.5	1.5	1.6	1.6	1.6	1.6	1.7	1.7	1.8
4.5	1.1	1.5	1.5	1.5	1.5	1.6	1.6	1.7	1.7	1.7	1.7	1.7	1.8	2.0
5.0	1.1	1.5	1.5	1.5	1.5	1.6	1.7	1.8	1.8	1.8	1.8	1.9	2.0	2.3
5.5	1.2	1.5	1.5	1.5	1.6	1.7	1.8	1.9	1.9	2.0	2.0	2.1	2.3	2.5
6.0	1.2	1.5	1.5	1.5	1.6	1.8	1.9	2.0	2.0	2.1	2.1	2.2	2.4	2.8
6.5	1.2	1.5	1.5	1.6	1.7	1.9	2.0	2.1	2.1	2.2	2.2	2.3	2.7	3.0
7.0	1.2	1.5	1.5	1.6	1.8	2.0	2.1	2.2	2.2	2.3	2.4	2.5	2.8	3.3
7.5	1.3	1.5	1.6	1.7	1.9	2.1	2.2	2.3	2.3	2.4	2.5	2.6	3.0	3.5
8.0	1.3	1.5	1.6	1.7	1.9	2.1	2.2	2.4	2.4	2.5	2.6	2.7	3.1	3.8
8.5	1.4	1.6	1.7	1.8	2.0	2.2	2.3	2.5	2.6	2.7	2.8	2.9	3.3	4.1
9.0	1.4	1.7	1.7	1.8	2.0	2.3	2.4	2.6	2.7	2.8	2.9	3.0	3.6	4.3
9.5	1.4	1.7	1.8	1.9	2.1	2.4	2.5	2.7	2.8	2.9	3.0	3.2	3.8	4.6
10.0	1.5	1.8	1.9	2.0	2.2	2.4	2.6	2.8	2.9	3.0	3.1	3.3	4.0	4.8

Take the nearest higher value for all intermediate height and length values.
*Possible nil setback in accordance with clause 6.3.2 of design element 6.3.

Table 2b - Boundary setbacks

Walls with major openings														
	Wall length (m)													
Wall height (m)	9 or less	10	11	12	13	14	15	16	17	18	19	20	25	Over 30
3.5 or less	1.5	1.5	1.5	1.5	1.5	1.5	1.5	1.5	1.5	1.5	1.5	1.5	1.5	1.5
4.0	1.8	2.0	2.2	2.4	2.5	2.7	2.8	3.0	3.1	3.3	3.4	3.6	4.5	5.0
4.5	2.0	2.2	2.4	2.6	2.8	3.0	3.1	3.2	3.4	3.7	3.8	4.0	4.8	5.4
5.0	2.3	2.5	2.6	2.8	3.0	3.2	3.3	3.5	3.7	3.9	4.0	4.2	5.1	5.7
5.5	2.5	2.7	2.9	3.1	3.3	3.5	3.6	3.7	3.9	4.2	4.4	4.6	5.5	6.0
6.0	2.8	3.0	3.1	3.3	3.5	3.8	3.9	4.0	4.2	4.5	4.7	4.9	5.7	6.3
6.5	3.0	3.2	3.4	3.6	3.8	4.1	4.1	4.2	4.4	4.7	4.9	5.2	6.1	6.6
7.0	3.3	3.5	3.7	3.8	4.1	4.3	4.4	4.6	4.8	5.0	5.2	5.5	6.4	7.0
7.5	3.5	3.7	3.9	4.2	4.4	4.6	4.7	4.9	5.1	5.3	5.5	5.7	6.6	7.3
8.0	3.8	4.0	4.2	4.4	4.6	4.9	5.0	5.2	5.4	5.6	5.8	6.0	7.0	7.7
8.5	4.0	4.3	4.5	4.7	4.9	5.2	5.3	5.5	5.7	5.9	6.1	6.3	7.3	8.0
9.0	4.3	4.5	4.7	5.0	5.2	5.4	5.6	5.8	6.0	6.2	6.4	6.6	7.6	8.3
9.5	4.6	4.8	5.0	5.2	5.4	5.7	5.8	6.0	6.2	6.4	6.6	6.9	8.0	8.7
10.0	4.8	5.0	5.2	5.4	5.7	6.0	6.1	6.3	6.5	6.7	6.9	7.2	8.2	9.0

Take the nearest higher value for all intermediate height and length values.

Table 3 - Maximum building heights

Maximum building heights (i)			
	Category		
	A	B	C
Top of external wall (roof above) (ii)	3 m	6 m	9 m
Top of external wall (concealed roof)	4 m	7 m	10 m
Top of pitched roof (iii) (iv)	6 m	9 m	12 m

- i Category B will apply unless a local planning policy requires the application of category A (generally single level development) or category C (development on three levels) or an alternative standard.
- ii Gable walls above eaves height:
 - less than 9 m long: exempted
 - greater than 9 m long: add one third of the height of the gable, between the eaves and the apex of the gable wall, to the eaves height.
- iii Applies to ridges greater than 6 m long. Short ridges: add 0.5 m height for each 2 m reduction in length.
- iv Applies to roof pitches up to 25 degrees. In some localities steeper pitches may be required and greater height permitted in accordance with the provisions of the scheme or local planning policy.



State Planning Policy 3.1

Residential Design Codes (Variation 1)

State Planning Policy 3.1

Residential Design Codes

(Variation 1)

R Codes

Figures

Figure 1a, 1b and 1c - Street setbacks

Figure 2a, 2b and 2c - Measurements of boundary setbacks

Figure 2d and 2e - Measurements of boundary setbacks

Figure 3 - Boundary setbacks

State Planning Policy 3.1

Residential Design Codes (Variation 1)

Figure 1a, 1b and 1c - Street setbacks

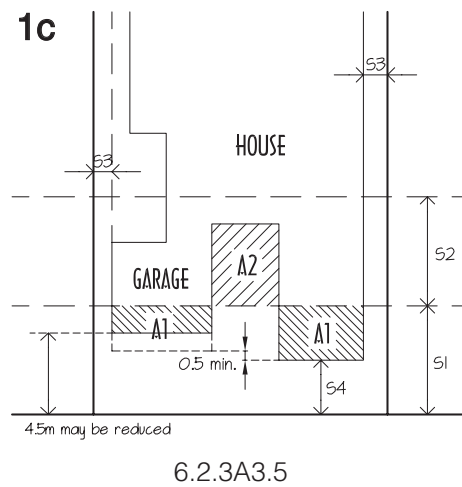
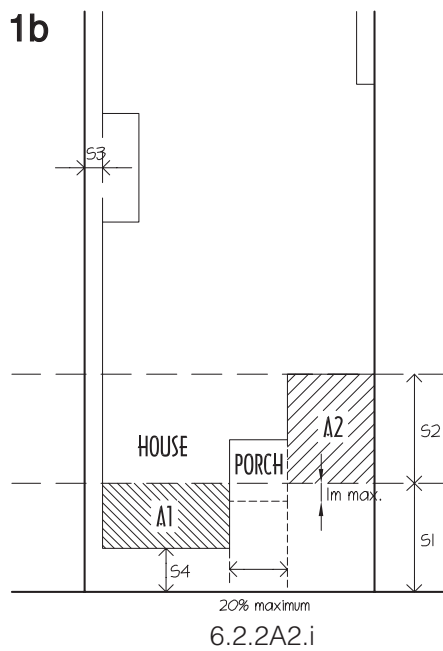
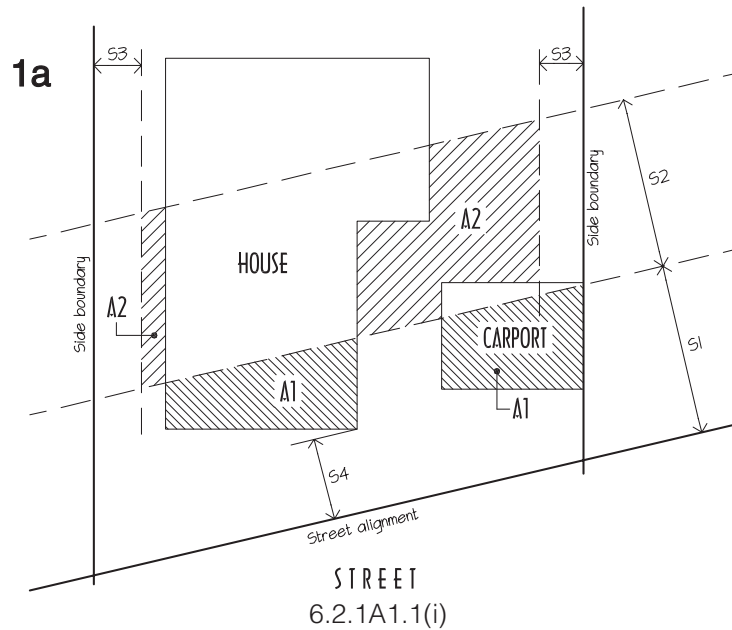

- S1 Prescribe street setback distance (Table 1 or average of setbacks either side).
- S2 Distance equal to S1.
- S3 1 m where wall of building is less than 3.5 m in height and less than 9 m in length with no major openings as specified in Table 2a.
- S4 Reduced street setback (not less than half of S1).
- A1 Areas of incursion into street setback area.
- A2 Compensating area behind prescribed street setback area.

Figure 2a, 2b and 2c - Measurements of boundary setbacks

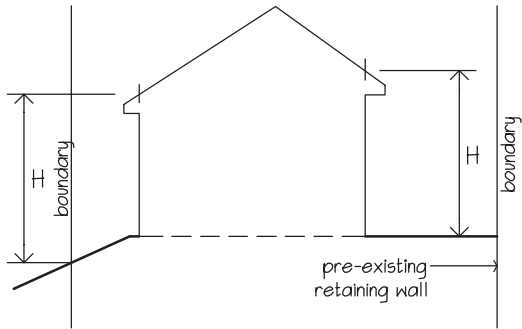

2a Cross-section

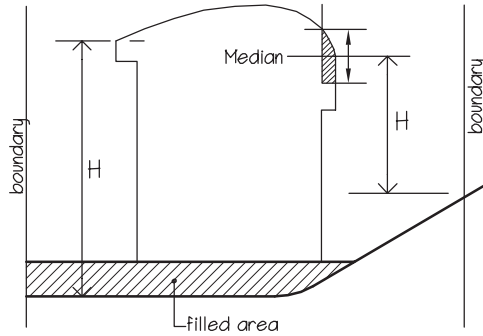

2b Cross-section

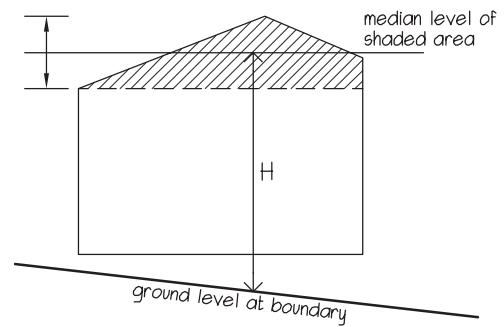

2c Elevation

Figure 2d and 2e - Measurements of boundary setbacks

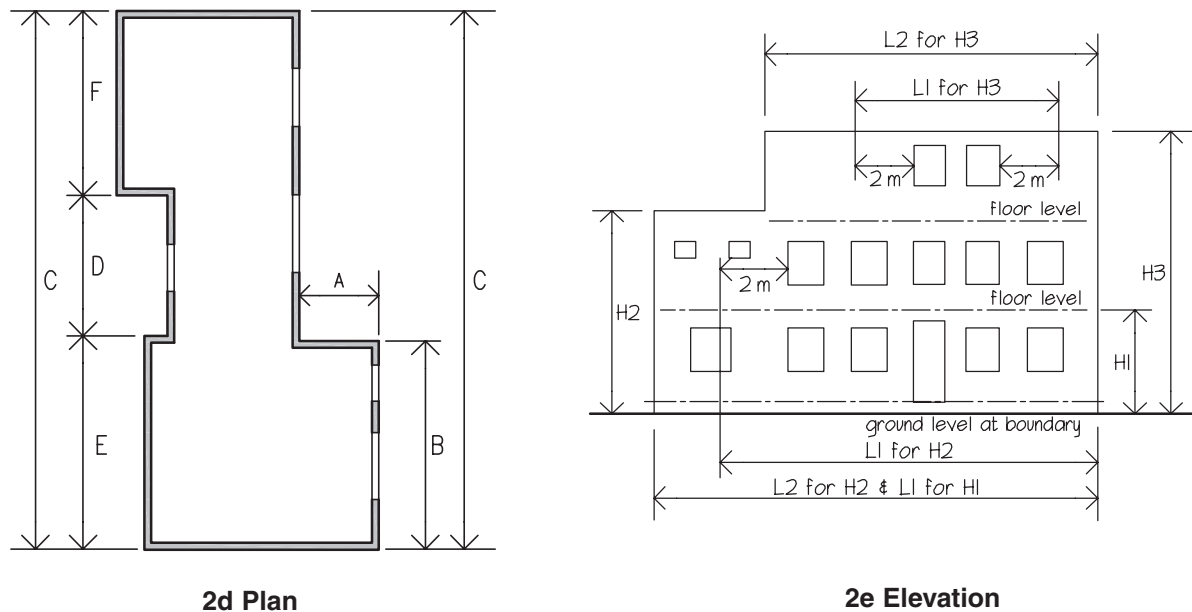

2d Plan

2e Elevation

Measurement of length of wall for calculating setbacks

For the purpose of calculating setbacks, length of wall means the total horizontal dimension of the side of the building nearest the boundary. Setbacks shall be determined in accordance with the following:

Figure 2d indicates the method for establishing setback measurements under table 2a and 2b, subject to the privacy requirements of element 8:

- Where A is more than 3 m, B shall be treated as a separate wall, providing that the length C shall be the basis for determining the setback of the rest of the side of the building.
- Where the side of a building includes one portion of a wall without a major opening (such as E or F), the setback shall be determined independently providing the setback of the rest of that side of the building is determined on the basis of the total length C.
- Where the side of the building includes two or more portions of a wall without a major opening (such as E and F) their setbacks shall be determined independently of each other provided they are separated from one another by a distance (D) of more than 4 m (in the case of wall heights of 6 m or less) and an additional 1 m for every 3 m increase in height.
- The setback of D shall be determined on the basis of the total length (C).

Figure 2e indicates the setback requirements for walls with major openings at different heights (H) whereby:

- The length of walls with major openings (L1) is calculated as the lesser of the actual length of wall or from a point 2 m beyond each major opening.
- Setback requirements for walls without major openings are shown as L2 and calculated from table 2a and figure 3.

Figure 3 - Boundary setbacks

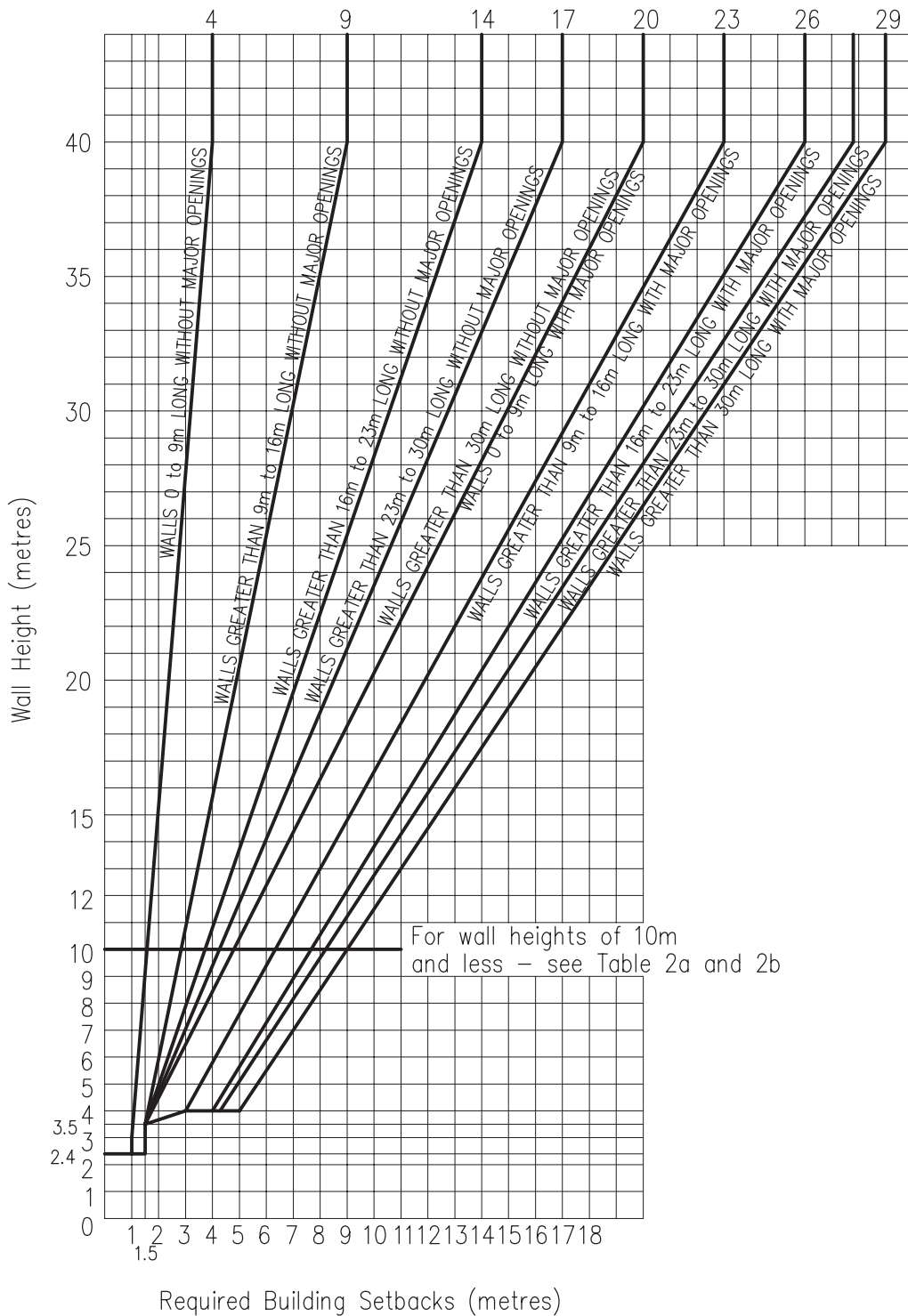

Notes:

- Intermediate values for wall heights over 10m are to be obtained by interpolation